

Description: Paint the USDC Annex 2nd, 4th, and 6th Floor Corridors

Date: July 5, 2018

Scope:

1	Patch and paint the 2nd, 4th, and 6th floor corridor walls highlighted below Benjamin Moore 916 "Cookie Dough" with an eggshell finish or equivalent.
---	---

2nd Floor

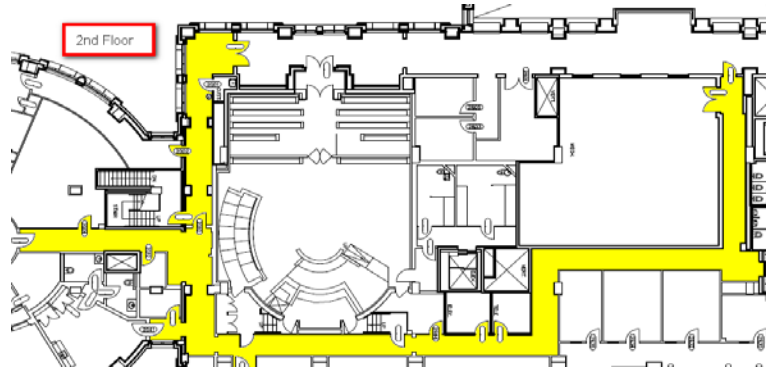

4th Floor

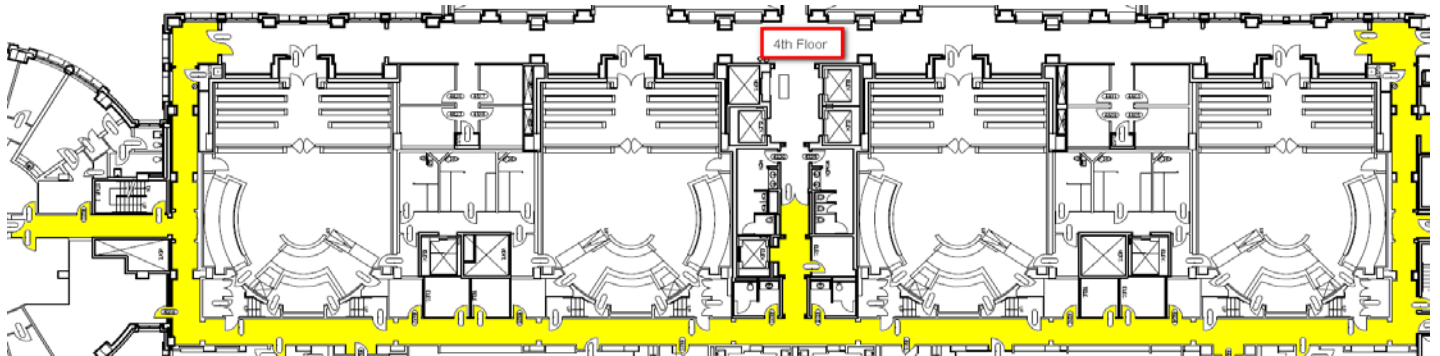

6th Floor

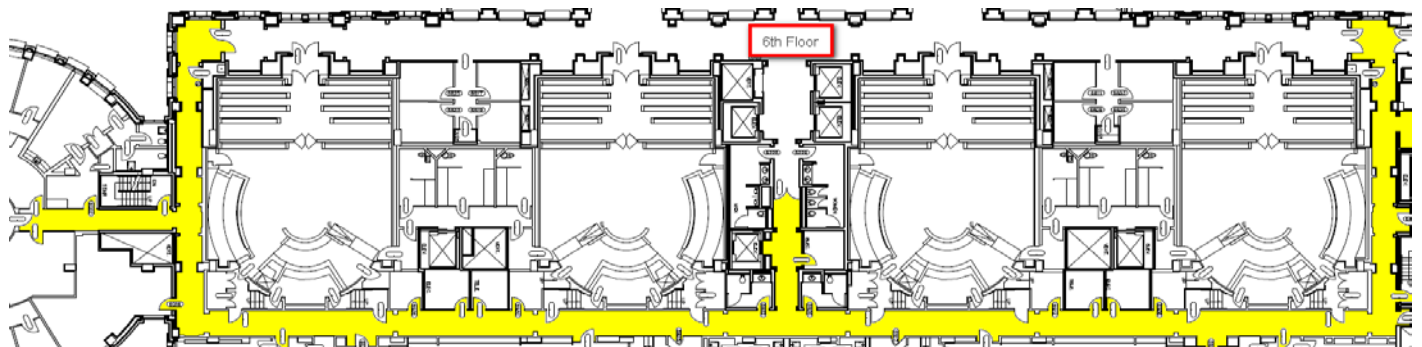

Terms:

	1 Contact Ernest Gambrell to schedule a review of the space in advance of proposal submission.
--	--

	<p>Contractor to submit name, date of birth, and social security number of all workers that will be working on site for this work scope. Submit information after being notified that the proposal has been accepted by the courts. A background check will be performed against the information provided. A purchase order will be issued upon notification that workers are suitable to work, unescorted, in the courthouse. Should it be determine that workers are not suitable a purchase order will not be issued. In this event, an explanation will not be provided; all decisions are final. <u>Not applicable to workers who have already been cleared to work in the building in the preceding six months.</u></p>
3	<p>Contractors shall work in assigned space only. Contact Ernest Gambrill at 202.354.3014 for escorted access to and from the work location.</p>
4	<p>Work shall be done on weekends or outside of normal working hours (Monday through Friday, 7:00 a.m. to 5:00 p.m.) and/or weekends (8 AM - 4 PM)</p>
5	<p>Contractor shall take all necessary steps to protect the existing space, typically including plastic protection over nearby surfaces. Contractor shall move furniture and equipment as necessary to complete work. The courts shall move computers, phones, and electronic equipment as necessary.</p>
7	<p>Provide proposal no later than July 12, 2018.</p>
8	<p>Work shall be completed no later than August 19, 2018.</p>

Direct any questions regarding the scope of work to Ernest Gambrill at 202.354.3014.